

# CME350P-1000 Series

## Instruction Manual

### BEFORE USING THE POWER SUPPLY UNIT

Be sure to read this instruction manual thoroughly before using this product. Pay attention to all cautions and warnings before using this product. Incorrect usage could lead to an electrical shock, damage to the unit or a fire hazard.

#### DANGER

Never use this product in locations where flammable gas or ignitable substances are present.

#### INSTALLATION WARNING

- When installing this product, ensure that work is done in accordance with the instruction manual. When installation is improper, there is risk of electric shock and fire.
- Installation shall be done by service personnel with necessary and appropriate technical training and experience. There is a risk of electric shock and fire.
- Do not cover the product with cloth, paper and etc. Do not place any flammable object around the product. This might cause damage, electric shock or fire.

#### WARNING ON USE

- Do not touch this product or its internal components while product is in operation, or shortly after shutdown. You may receive a burn.
- While this product is operating, keep your hands and face away from it as you might get injured from an unexpected situation.
- For product without cover, do not touch this product or its internal components while product is in operation, or shortly after shutdown. There are high voltage potential and high temperature parts in the product. This might cause injury such as electric shock or burn.
- There are cases where high voltage charge remains inside the product immediately after the input is cut off. Do not touch even if product is not in operation as you may get injured from electrical shock and burn.
- Do not make unauthorized change to this product or remove the cover as you may get injured from electric shock or damage the product. We will not be held responsible if the product was modified, changed or disassembled.
- Do not use this product under unusual conditions such as emission of smoke or abnormal smell and sound etc. Please stop using it immediately and shut off the product. It might lead to fire and electric shock.  
In such cases, please contact to TDK-Lambda. Do not attempt any repair by yourself, as this may cause injuries to yourself.
- Do not operate and store these products in environments where condensation occurs due to moisture and humidity. It might lead to fire and electric shock.
- Do not use the product when there is mechanical over-stress or heavy impact to the product as it might cause failure.
- When necessary, this product is to be repaired by TDK-Lambda or our authorized agents. It is important that this product must not be used in hazardous environments or facilities such as nuclear power control system or life support equipment without our written consent.

#### CAUTION ON MOUNTING

- Ensure connections to input/output terminals are correct as indicated in the instruction manual before switching on.
- Input voltage, Output current, Output power, ambient temperature and ambient humidity should be kept within specifications, otherwise the product will be damaged.
- Input wires must be as short and thick as possible.
- Do not use this product in special environment with strong electromagnetic field, corrosive gas or conductive substances and direct sunlight, or places where product is exposed to water or rain.
- Mount this product properly in accordance with the instruction manual, mounting direction and shall be properly ventilated.
- Please shut down the input when connecting input and output of the product.
- When installing in environment where conductive foreign, dust and liquid may be present, please consider penetration of these foreign material in the power supply by installing filter, to prevent trouble or malfunction.
- Please install power supply in a fire enclosure.
- There is a case where the baseplate becomes high temperature. The equipment should be re-evaluated the power supply to comply the heat resistant temperature of the equipment.

**⚠ CAUTION ON USE**

- Product individual notes are shown in the instruction manual. If there is any difference with common notes, individual notes shall have priority.
- Before using this product, be sure to read the catalog and instruction manual. There is risk of electric shock or damage to the product or fire due to improper use.
- Input voltage, Output current, Output power, ambient temperature and ambient humidity should be kept within specifications. Otherwise the product will be damaged, or cause electric shock or fire.
- If the internal fuse is blown, do not use the product even after replacing the fuse, as there is risk of abnormality inside. Be sure to request repair to our company.
- For products without built-in protection circuit, insert fuse at the input to prevent smoke, fire during abnormal operation. As for products with built-in protection circuit, depending on usage conditions, built-in protection circuit might not work. It is recommended to provide separate proper protection circuit.
- For externally mounted fuse do not use other fuses aside from our specified and recommended fuse.
- This product is made for general purpose electronic equipment use and is not designed for applications requiring high safety such as extremely high reliability and safety requirements. Even though high reliability and safety are not required, this product should not be used directly for applications that have serious risk to life and physical safety. Take sufficient consideration in fail-safe design such as providing protective circuit or protective device inside the system, providing redundant circuit to ensure no instability when single device failure occurs.
- When used in environment with strong electromagnetic field, there is a possibility of product damage due to malfunction.
- When used in environment with corrosive gas (hydrogen sulfide, sulfur dioxide, etc.), there is possibility that it might penetrate the product and result in failure.
- When used in environment where there is conductive foreign matter or dust, there is possibility of product failure or malfunction.
- Provide countermeasure for prevention of lightning surge voltage as there is risk of damage due to abnormal voltage.
- Connect together the frame ground terminal of the product and the ground terminal of the equipment for safety and noise reduction. If these ground is not connected together, there is risk of electric shock.
- Parts with lifetime specifications (electrolytic capacitor) is required to be replaced periodically. Set the overhaul period depending on the environment of usage and perform maintenance. Also, note that there are cases when EOL products cannot be overhauled.
- Take care not to apply external abnormal voltage to the output. Especially, applying reverse voltage or overvoltage more than the rated voltage to the output might cause failure, electric shock or fire.
- This product is designed under condition Material group III b, Pollution Degree (PD): PD2, Over Voltage Category (OVC): OVC II in IEC/UL/CSA/EN 62368-1, OVC III in IEC/EN 62477-1 and Class of equipment: Class I. This product is designed to be accessible only to service technicians as part of indoor use device.
- This product contains a Printed Circuit Board (PCB) utilizing Surface Mounted Devices. PCB stress such as bending might cause SMD damage. Please handle with care.
- When handling this product, hold the PCB edge or base plate, and take care not to touch the component side.
- The outputs of this product may exceed ES1 limits under fault conditions. The outputs must be protected in the end equipment to maintain ES1.
- The output power of this product is considered to be hazardous energy level. (The voltage is more than or equal to 2V and the power is more than equal to 240VA) It must not be made accessible to users. Protection must be provided for service engineers against indirect contact with the output terminal and to prevent any tools drop across the outputs. While working on this product, the AC input must be switched off and the input and output voltage should be zero.

**⚠ SPECIAL INSTRUCTION FOR IEC/EN/ES/CSA 60601-1**

- The product is designed on the premise where it is mounted into enclosure that is restricted access from the outside.
- Avoid access to the mains and output terminal from outside.
- The product is not suitable for use in the presence of flammable anesthetics that is mixed with the air, oxygen and nitrous oxide.
- The output circuit has not evaluated for connecting to Applied Parts. If the equipment intends to connect the output circuit to Applied Parts, the equipment should be re-evaluated the related requirements e.g. isolation resistance, leakage current, dielectric voltage.
- The product is equipped double pole fuse / neutral fusing. 
- The product provides One Means Of Patient Protection (1MOPP) for the primary to FG and the primary to FG. Two Means Of Patient Protection (2MOPP) is provided for the primary circuit to the secondary circuit.
- The product is classified as IPX0.

**⚠ NOTE**

- Take note that visible scratches and traces on metal surface may exist on the product.
- When disposing the product, follow disposal laws of each municipality.
- Published EMI (CE, RE) or immunity is the result when measured in our standard measurement conditions and might not satisfy specification when mounted and wired inside end-user equipment. Use the product after sufficiently evaluating at actual end-user equipment.
- When exporting our products, apply for necessary permissions as required by rules and regulations of Foreign Exchange and Foreign Trade Control Act.
- Catalogue or contents of the instruction manual may be changed without a prior notice. Refer to latest catalogue or instruction manual.
- Reproduction or reprinting the instruction manual or its portion is forbidden unless with TDK-Lambda authorization.
- CE Marking. When applied to a product covered by this handbook, indicates compliance with the low voltage directive.

**⚠ LONG-TERM STORAGE METHOD AND DURATION PERIOD**

- Always keep the product in carton box.
- Please do not apply excessive vibration, shock or mechanical stress directly to the product.
- Please keep away from direct sunlight.
- For long-term storage temperature and humidity, the following conditions are recommended :
  - Temperature range : 5°C~30°C
  - Humidity range : 40%~60%RH
  - Avoid places where its temperature and humidity can change drastically.
  - It might cause product degradation or condensation on the product.
- For long-term storage period, we recommend to use within 2 years after receiving the product.
  - There is tendency that the leakage current of an aluminum electrolytic capacitor may increase when not use for a long time. This phenomenon can be improved by applying voltage to the aluminum electrolytic capacitor to reduce the leakage current through the self-recovery effect of the electrolyte.
  - For products that have been stored for a very long time, it is recommended to turn on the product for at least 30 min at no load condition.
  - < Criterion of warm up voltage condition >
    - (1)Implementation period : 1 year or above after the delivery
    - (2)Electrical condition
      - Input voltage : Rated
      - Load : 0A
      - Ambient temperature : Nominal temperature
      - Time : 30 minutes or more

**1. Model name identification method**

**CME 350 P - 1000 - 24 / □**

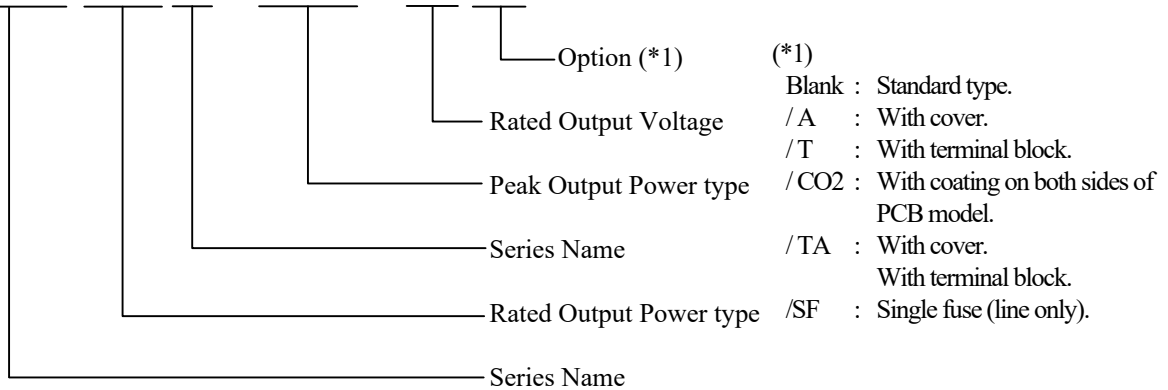

**2. Terminal Explanation**

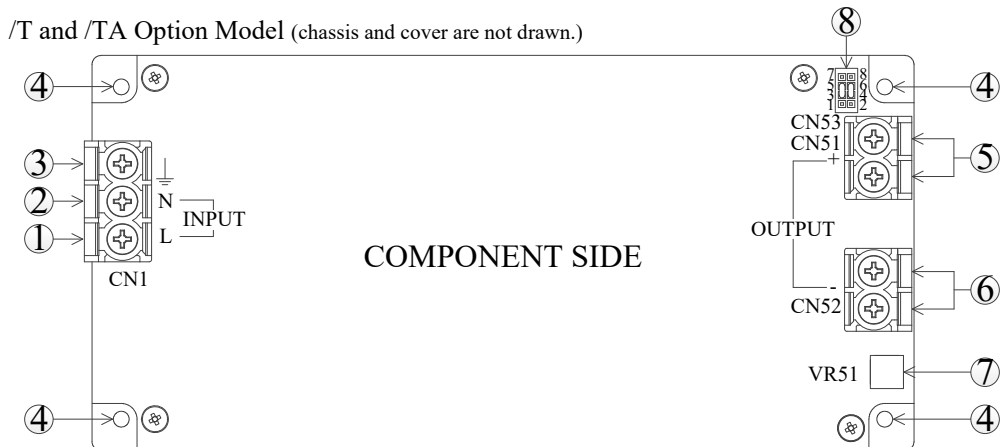
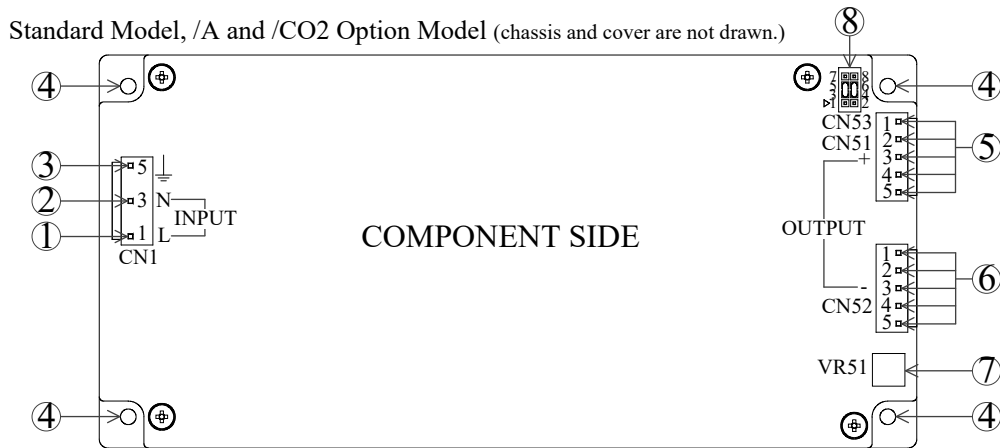

- ① L : Input terminal Live line (Fuse in line.) (CN1)
- ② N : Input terminal Neutral line (Fuse in line.) (CN1)
- ③ ⊥ : Earth (⊥) Terminal (CN1)
- ④ Mounting hole (hole diameter : 3.5mm)  
 These holes are connected to ⊥ terminal of CN1.  
 Must be connected to Chassis (Conductor) of the equipment by screw or metal spacer.
- ⑤ + Output Terminal (CN51)
- ⑥ - Output Terminal (CN52)
- ⑦ Output Voltage Adjust Trimmer.
- ⑧ Signal Connector (CN53)

**CN53 Signal Connector Pin Configuration and Function**

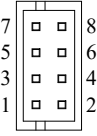
	Pin No.	Configuration	Function
	1	-R	GND for remote ON/OFF control terminal.
	2	+RO	Remote ON/OFF control terminal. External switch is required and switch open to turn-on power supply. Do not connect to pin 6 and 8, and do not connect external voltage. If it is connected, power supply might cause malfunction.
	3	-R	GND for remote ON/OFF terminal.
	4	+RS	Remote ON/OFF terminal. External switch is required and switch short to turn on power supply.
	5	-STB	GND for standby supply.
	6	+STB	Standby supply (5V/0.3A). For further information, refer to 6-8.
	7	-STB	GND for standby supply.
	8	+STB	Standby supply (5V/0.3A). For further information, refer to 6-8.

**CN53 Connector**

Connector	Housing	Terminal Pin	Maker
B8B-PHDSS(LF)(SN)	PHDR-8VS	SPHD-002T-P0.5 (AWG#24 to AWG#28) or SPHD-001T-P0.5 (AWG#22 to AWG#26)	JST

Hand Crimping Tool : YRS-620 (SPHD-002T-P0.5) or YC-610R (SPHD-001T-P0.5) (JST)

Use maker recommended crimping tool.

The following signal pins shall be connected by jumper connector at time of shipment :

CN53 : +STB terminal (pin No.6) - +RS terminal (pin No.4)

-STB terminal (pin No.5) - -R terminal (pin No.3)

### 3. Block Diagram

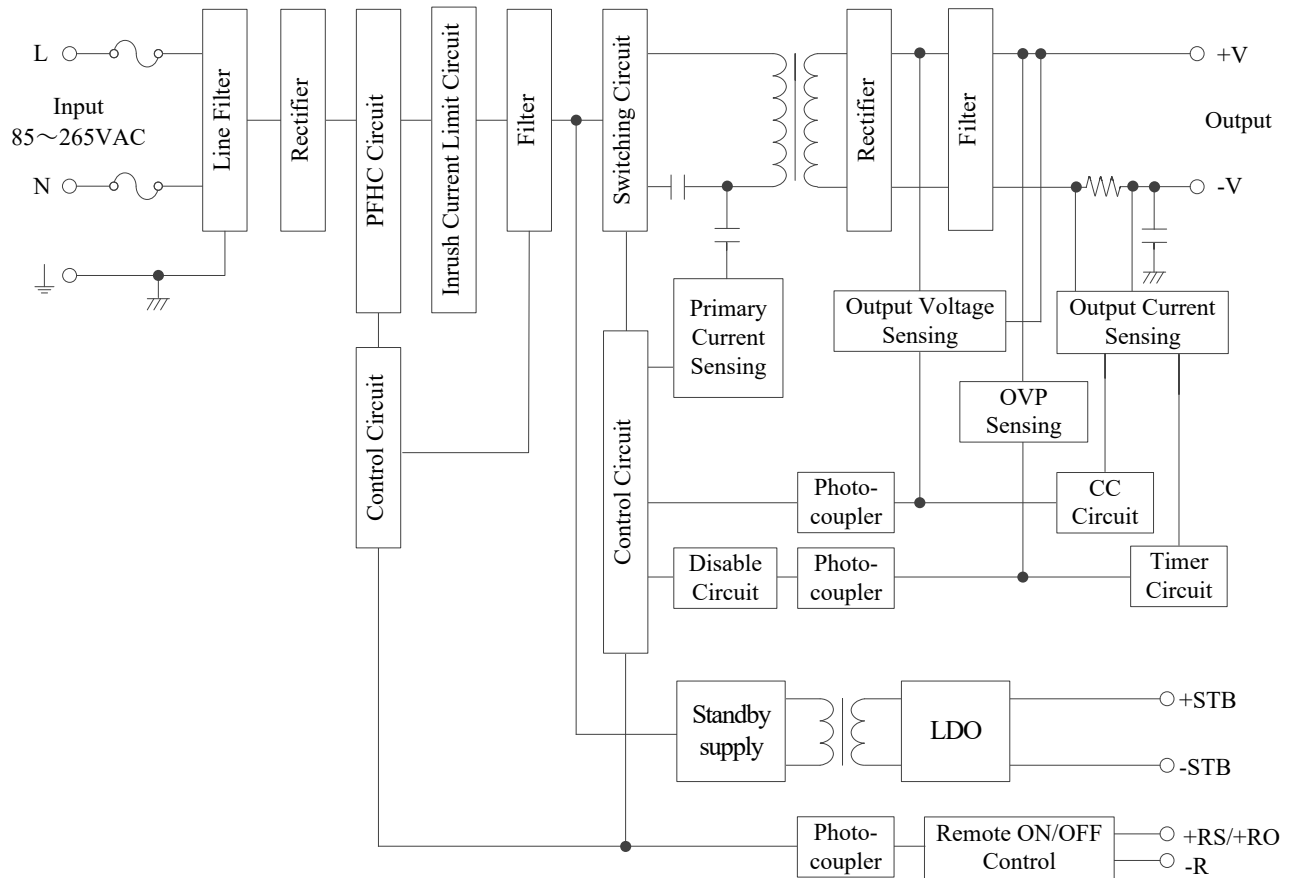

Circuit topology, switching frequency

Switching circuit : LLC resonant converter (\*)

75kHz to 120kHz

\*At light-load or no-load condition, switching will be in burst-mode at intermittent switching frequency.

PFHC circuit : active filter

100kHz (fixed)

Standby supply : flyback converter

100kHz (jittering)

Fuse rating

16A

## 4. Sequence Time Chart

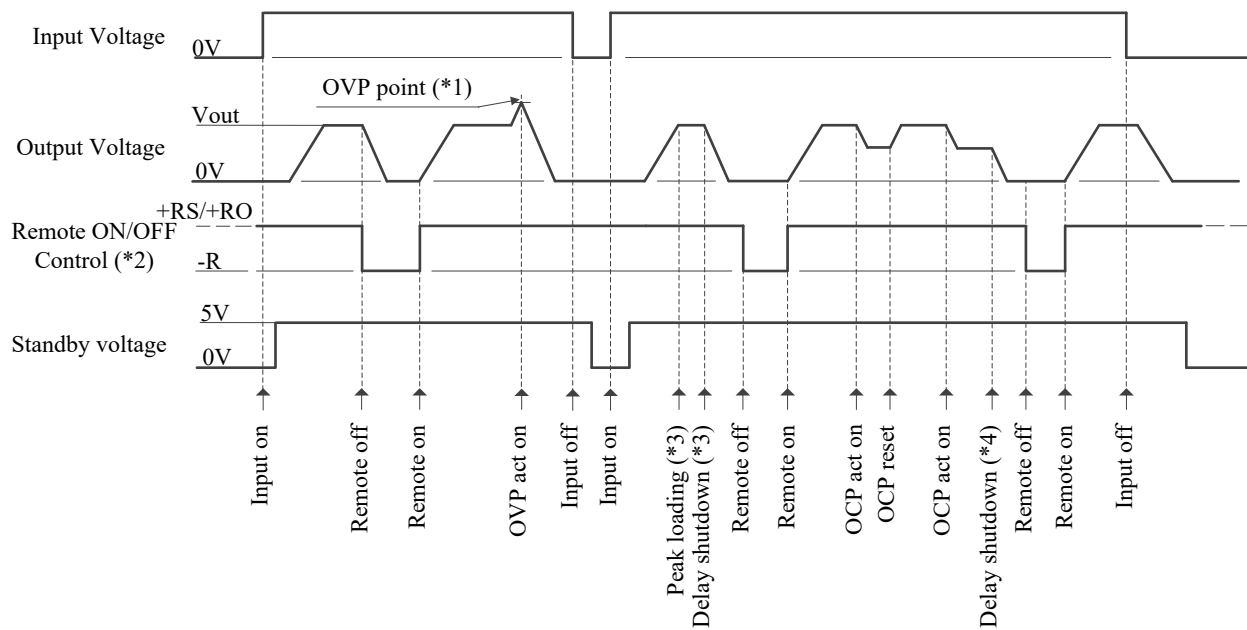

(\*1) OVP detection point is fixed as follows.

24V: 28.1V - , 30V: 31.1V - , 36V: 44.1V - and 48V: 50.1V -

(\*2) External switch is required. Refer to section 6-14 "Remote ON/OFF control".

(\*3) Peak loading duration more than specified timing is caused output to shutdown (delay shutdown).

e.g. More than 5 sec at 800W peak loading, More than 1 sec at 1000W peak loading.

Delay shutdown time is depended on peak loading.

(\*4) OCP condition more than 1 sec is caused output to shutdown (delay shutdown).

## 5. Terminal Connection Method

Pay attention to the input wiring. If it is connected to wrong terminal, the power supply will be damaged.

- When making connections, the input must be off.
- ⊥ terminal must be connected to protective earth (flame ground of the equipment and etc.) by thick wire for safety and improvement of noise sensitivity.
- Output current of each connector pin (standard model, /A, and /CO2 option model) must be less than 10A and the output current of each terminal block pin (/T and /TA option model) must be less than 30A.
- The output load line and input line shall be separated to improve noise sensitivity.
- When connecting or removing connector, do not apply stress to PCB.
- Use input/output connector (housing) and the crimp type terminal specified by the table below. Connector or crimp type terminal is not included with this product.
- Use recommended crimping tool. (Refer to the following)

Standard Model, /A and /CO2 Option Model (chassis and cover are not drawn)

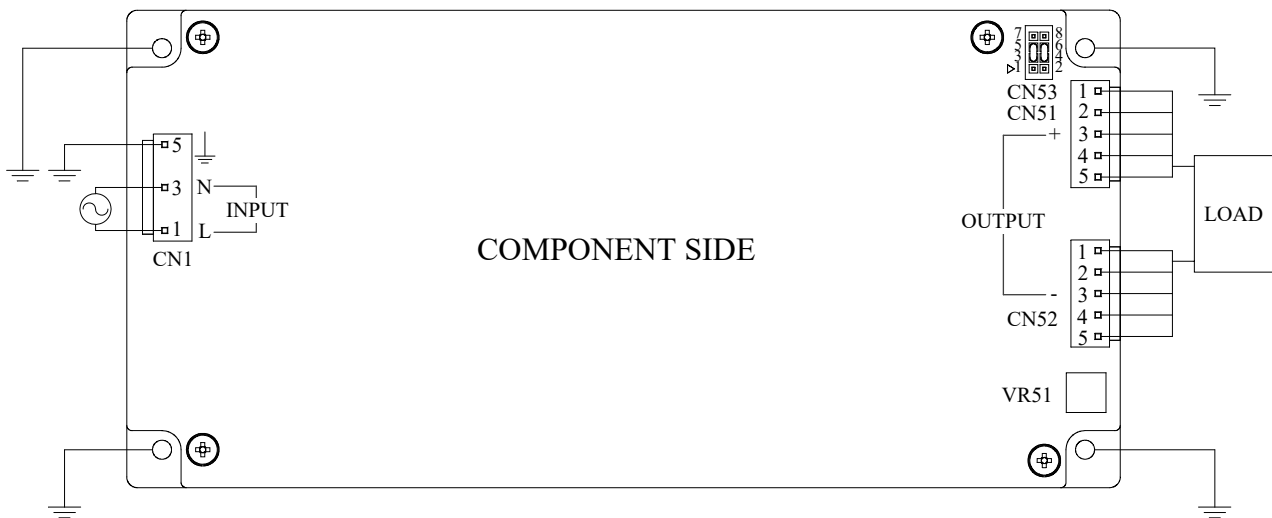

### Input Connector (CN1) / Output Connector (CN51, CN52)

	Connector	Housing	Terminal Pin	Maker
Input ( CN1 )	B3P5-VH(LF)(SN)	VHR-5N	SVH-41T-P1.1	JST
Output ( CN51 & CN52 )	B5P-VH(LF)(SN)	VHR-5N	SVH-41T-P1.1	JST

Hand Crimping Tool : YC-930R (JST)

The recommended wire size are AWG #22 ~ #16.

### Signal Connector (CN53)

	Connector	Housing	Terminal Pin	Maker
CN53	B8B-PHDSS(LF)(SN)	PHDR-8VS	SPHD-002T-P0.5 SPHD-001T-P0.5	JST

Hand Crimping Tool : YRS-620 (JST)

The recommended wire size is AWG #28 ~ #22.

/T and /TA Option Model (Chassis and cover are not drawn)

All terminals are M3.5 screws and recommended wire size is AWG #22 ~ #16.

The recommended tightening torque is 1.0 N·m ~ 1.6 N·m (10.2 kgf·cm ~ 16.3 kgf·cm).

When using separate loads, use of two pieces of 0.8 mm thick crimp type terminal is recommended. Refer to wire manufacture recommended allowable current and voltage drop for recommended diameter of crimp terminal.

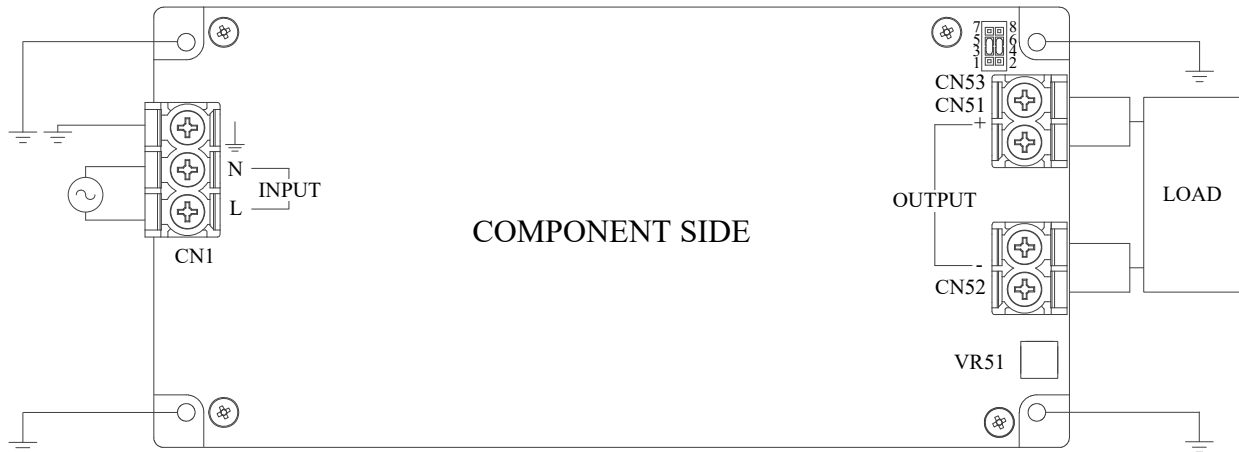

Recommended crimp type terminal		
D (MAX)	T (MAX)	No. of pieces (MAX)
6.8 mm	1.0 mm	1 piece
	0.8 mm	2 pieces

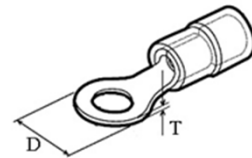

## **6. Explanation of Function and Precautions**

### **6-1. Input Voltage Range**

Input voltage range is single phase 85-265VAC(47-63Hz) or 120-370VDC.

Unit may damage if operate out of product specification. For cases where conformance to various safety standards are required, it is described as 100-240VAC (50-60Hz). Output derating is required for AC input voltage less than 90VAC. Refer to 7-4. Output Derating curve according to the Input Voltage.

### **6-2. Output Voltage Range**

Output voltage is set to rated value at shipment. Output voltage can be adjusted by output voltage adjustment trimmer (VR51). Refer to specification for output voltage range. The output voltage will be increased by turning VR51 clockwise. Take note that when the output voltage is increased excessively, over voltage protection (OVP) might trigger and the output will be shut down and manual reset of power supply or remote control off/on is required to re-power on. Furthermore, when the output voltage is set higher than rated output voltage, the output current is required to re-adjust so as not to exceed the maximum output power.

### **6-3. Inrush Current**

The relay method is used for limiting the inrush current. When input turn on interval is short, higher current might be flow. Take note that first inrush current and second inrush current will be flow. Required to select an appropriate input switch and external fuse.

### **6-4. Delay Shut Down**

Delay shut down function is provided to protect power supply and equipment from the overload condition (e.g. continuous peak loading more than specified duration) and the output short-circuit. The delay shut down time is fixed and its setting cannot set externally. Furthermore, the delay shutdown time is depended on the output current. When the delay shutdown is triggered, the output will shutdown and manual reset of power supply or remote control off/on is required to re-power on. Use this power supply within peak specification range. Refer to section "7-2. Peak Output" for peak loading details.

### **6-5. Over Current Protection (OCP)**

The constant current mode protection is equipped with automatic recovery. When the output current exceeds 101% of maximum peak output current of specification, OCP will operate and the output current will be maintained to constant current. When the overload condition is cancelled, the output will be automatically recovered. Never operate the unit under over current or shorted conditions, which might cause power supply to damage. OCP setting is fixed and it cannot set externally.

### **6-6. Over Voltage Protection (OVP)**

The OVP function is output shut down method with manual reset. When OVP is triggered, the output will shutdown and manual reset of power supply or remote control off/on is required to re-power on. The OVP set point is fixed and it cannot set externally. Never apply the voltage externally to the output terminal, it might cause power supply to damage. In case of inductive load is used, the protective diode is required to connect in series to the output line.

### **6-7. Over Temperature Shut Down**

When the ambient temperature or internal component temperature rise abnormally, over temperature shut down will trigger and the output will be shut down. When over temperature shutdown is triggered, turn off the power supply and allow it to cool down sufficiently, before re-power on the power supply by manual reset of power supply or remote control off/on. Over temperature shutdown function will operate out of specification. This function might not activate depending on the situation and there is case that over temperature shut down cannot avoid power supply damage.

### **6-8. Standby supply**

A fixed 5V standby supply is provided through +STB and -STB of CN53. The maximum output current of standby supply must be less than or equal to 0.3A. The maximum external capacitor across +STB and -STB is 1,000uF. Ensure that large capacitor is not connected across +STB and -STB.

### 6-9. Output Ripple and Noise

The standard specification for maximum ripple value is measured according to measurement circuit specified by JEITA-RC9131D. In the case of the output lines become longer, the electrolytic capacitor and film capacitor might be necessary to use across the load terminal to reduce output ripple and noise. If the probe ground lead of oscilloscope is too long, the output ripple and noise cannot be measure accurately.

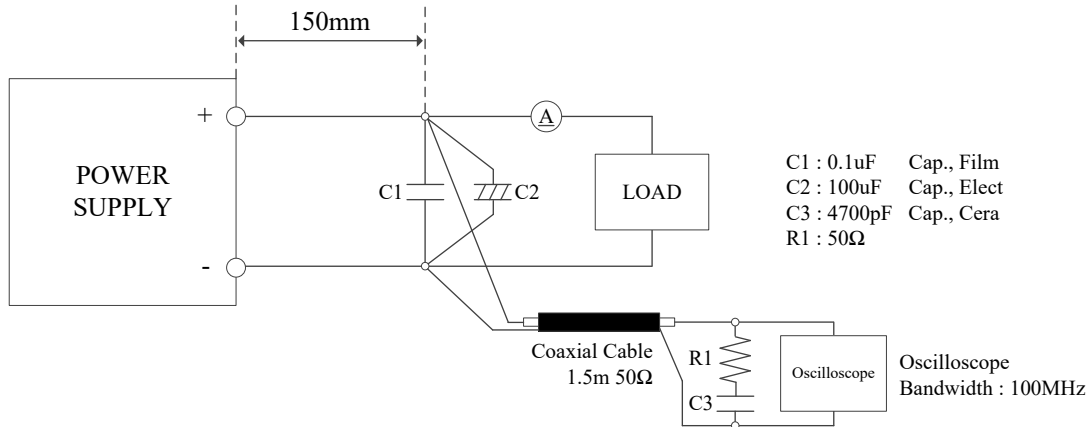

### 6-10. Series Operation

For series operation, either method (A) or (B) is possible.

#### Method (A)

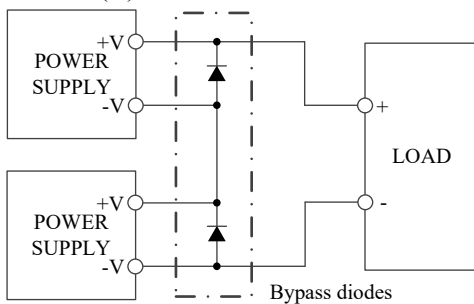

#### Method (B)

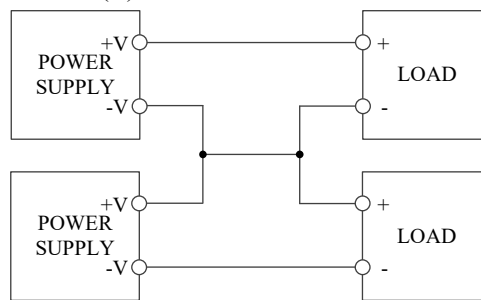

Note : Never use in condition that one of the units is not operated. It will cause power supply to damage.  
 When power supplies are connected as method (A), the bypass diode is required. The bypass diode must be selected with maximum forward current rating and maximum reverse voltage rating of more than output current and output voltage.

### 6-11. Parallel Operation

Method (A), that to increase the output current is not possible. If redundancy is required for equipment, protection diode must be inserted between power supply and load as Method (B).

If Method (B) is required, the following items should be considered.

1. Set the output voltage of power supplies higher by the forward voltage drop of protection diode.
2. Adjust the output voltage of each power supplies to be the same.
3. Use power supply within output voltage range and maximum output power in the standard specification.
4. Select protection diode with higher forward current rating than the output current.

#### Method (A)

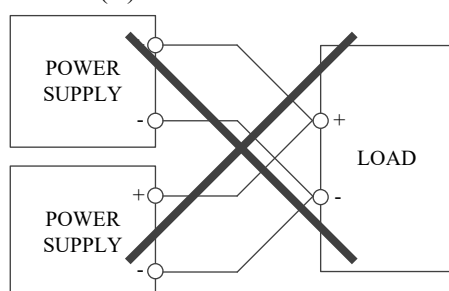

#### Method (B)

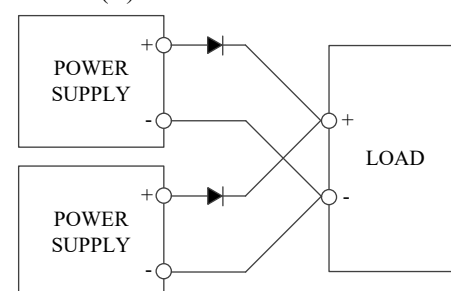

**6-12. Isolation Test**

Isolation resistance between Output -  $\perp$  terminal is more than 100M $\Omega$  at 500VDC. For safety operation, voltage setting of DC isolation tester must be done before the test. Ensure that the unit is fully discharged after the test.

- Output -  $\perp$  terminal : 500VDC More than 100M $\Omega$

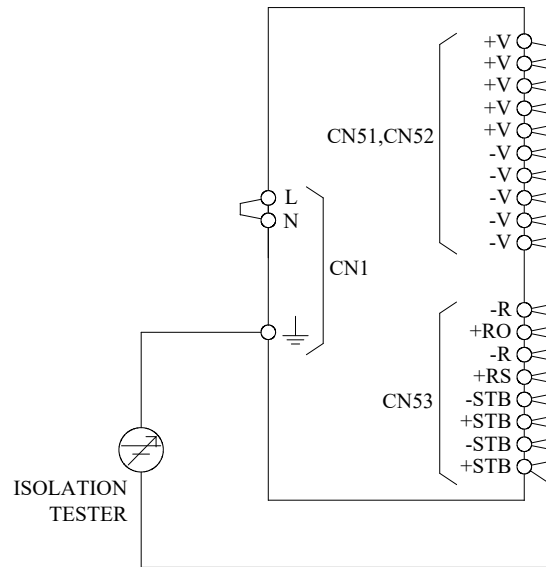

**6-13. Withstand Voltage**

This series is designed to withstand 4.0kVAC between input and output, 2.0kVAC between input and  $\perp$  terminal, and 1.5kVAC between output and  $\perp$  terminal each for 1 minute. When testing withstand voltage, set current limit of the withstand voltage test equipment to 10mA (output -  $\perp$  terminal : 20mA). The withstand voltage must be gradually increased from zero to the testing value and then gradually decreased for shut down. When timer is used, the power supply might be damaged by high impulse voltage at timer switch on and off. Connect input and output as follows.

- Input – Output (Dashed line) : 4.0kVAC, 1min (10mA)
- Output –  $\perp$  terminal : 1.5kVAC, 1min (20mA)
- Input –  $\perp$  terminal (Solid line) : 2.0kVAC, 1min (10mA)

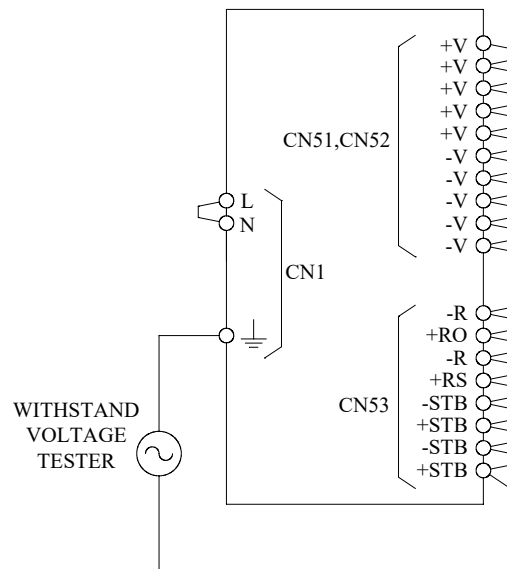
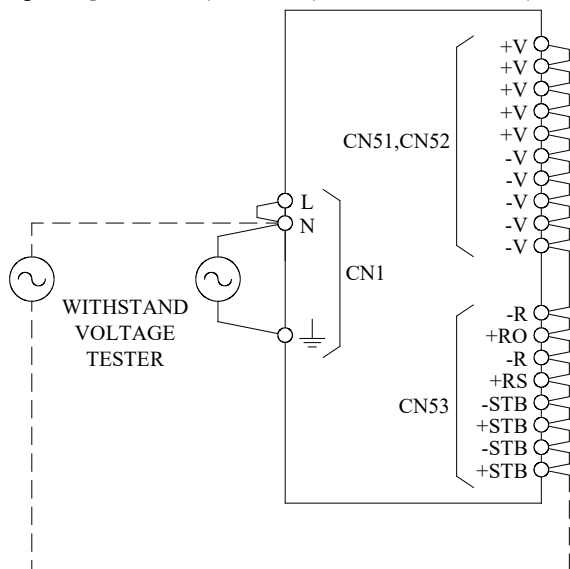

Note : In case of using external noise filter, capacitance between input and  $\perp$  terminal might be increased. When testing withstand voltage between input and output, there is a possibility of exceeding withstand voltage between output and  $\perp$  terminal (1.5kVAC). If the voltage between output and  $\perp$  terminal is exceeding 1.5kVAC, the external capacitor is required to place across output and  $\perp$  terminal. On the other hand, no need to check the voltage in case of output and  $\perp$  terminal is shorted.

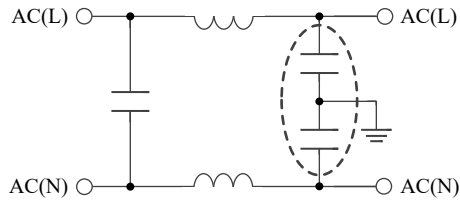

The example of noise filter circuit that might increase capacitance value between "input and  $\perp$  terminal". (Capacitance dashed line is added.)

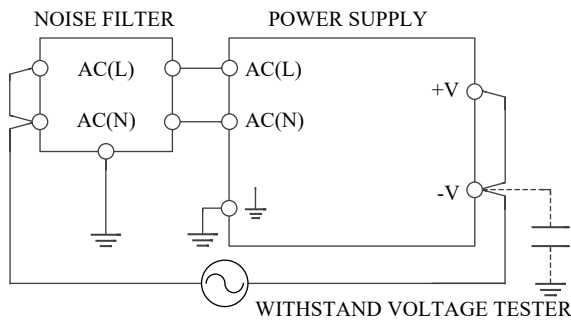

External capacitor value adding point or short point. Even in the case of "+V and  $\perp$  Terminal", it is a similar effect.

### 6-14. Remote ON/OFF Control

Remote ON/OFF control (CN53) function is provided. Using this function allows the user to turn the output on and off without recycle of AC input. Remote ON/OFF can be controlled by the voltage across +RS/+RO terminal and -R terminal. +STB terminal (pin No.6) - +RS terminal (pin No.4) and -STB terminal (pin No.5) - -R terminal (pin No.3) are connected by short piece (connector) at shipment. The short piece must be removed to perform remote ON/OFF control function. Remote ON/OFF circuit is in the secondary side of the power supply and it is isolated from output circuit. Never connect to the Primary side.

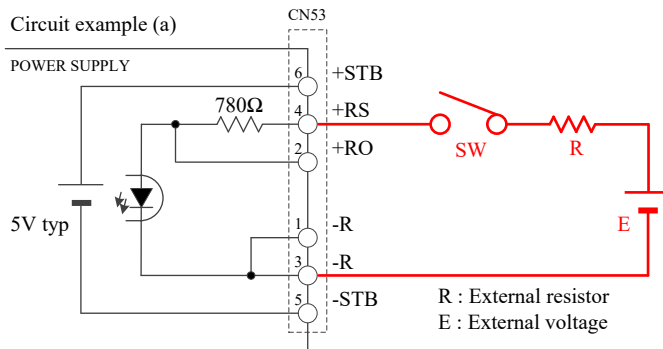

SW condition	Power supply output
Short	Turn ON
Open	Turn OFF

External voltage : E	External resistor : R
$4.5V \leq E < 12.5V$	Not required
$12.5V \leq E \leq 24.5V$	1.8k $\Omega$

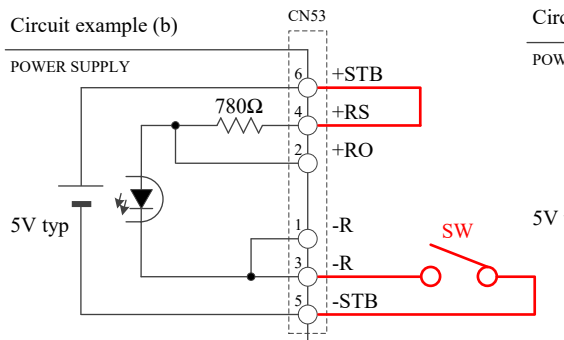

SW condition	Power supply output
Short	Turn ON
Open	Turn OFF

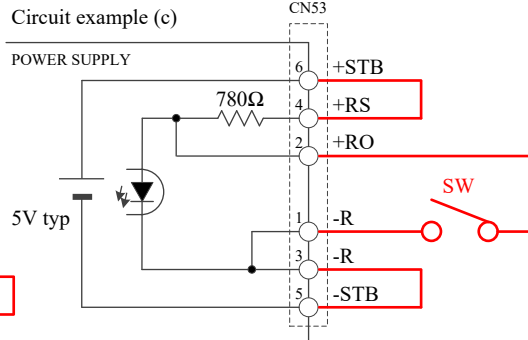

SW condition	Power supply output
Short	Turn OFF
Open	Turn ON

## 7. Mounting Directions

### 7-1. Mounting Directions

The standard mounting is direction (A). Direction (B) to (F) are also possible. Use power supply within the output derating (output power or current versus operating ambient temperature) according to mounting direction and actual operating ambient temperature. Refer to section 7-3 Output Derating according to the Mounting Direction. This series can be used under convection cooling and forced air cooling. In the case of using at forced air cooling, entire component must be cool down. An air velocity of more than 2.2m/s is required to flow through the power supply as a guide. For details, refer to section 7-3 FORCED AIR COOLING CONDITION.

Mounting A (Standard Mounting)

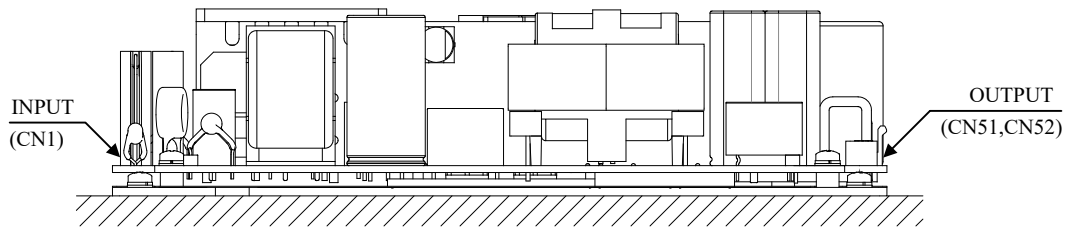

Mounting B

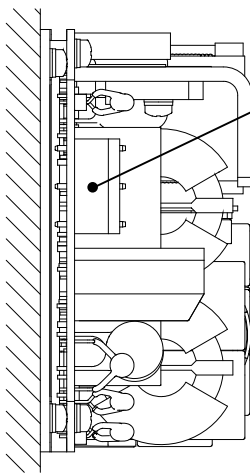

Mounting C

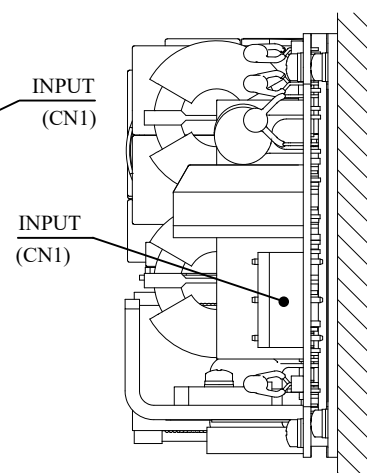

Mounting D

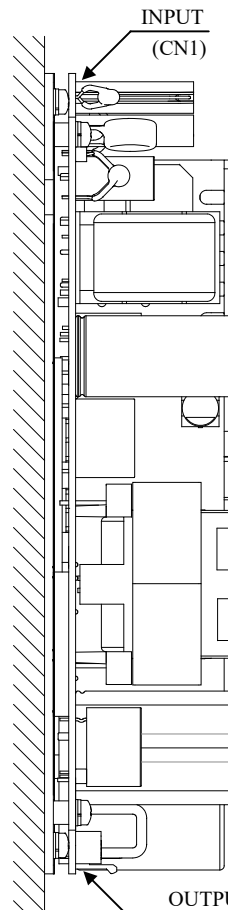

Mounting E

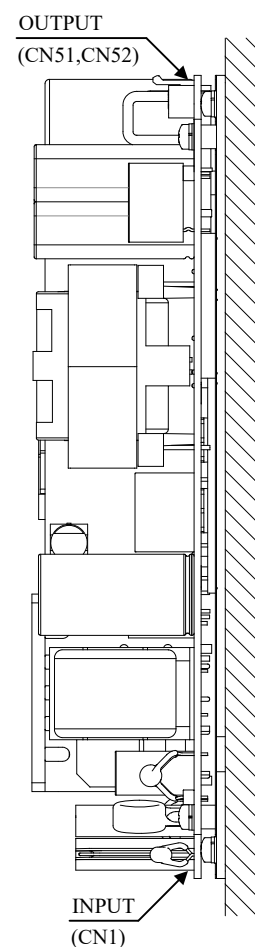

Mounting F

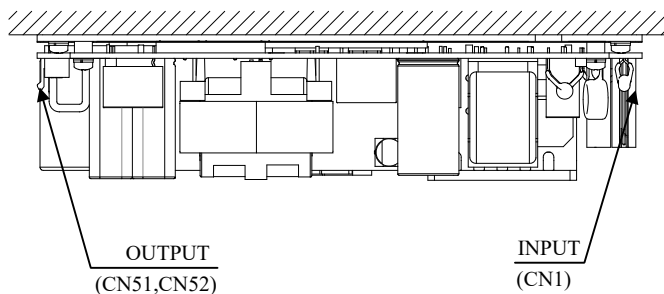

### 7-2. Peak Output

Continuous peak output duration must be less than or equal to 5 sec with duty not more than 45%. Peak output power more than 5 sec will cause output to shutdown by delay shut down and manual reset of power supply or remote control off/on is required to re-power on. Use power supply to satisfy (a) Peak Output Condition, (b) Peak Output Power versus Duty and (c) Peak Output Power Versus Pulse Width of Peak Output Power. In addition, the peak output condition must comply to all derating requirement : input voltage, mounting direction, convection cooling and forced air cooling. When the peak output power is more than 800W, the pulse width of peak current ( $\tau$ ) must be less than or equal to 1 sec. When input voltage is less than 170VAC, output derating is required. Refer to (d) Output Derating curve according to the Input Voltage at Peak Loading for details. The product might be damaged if use beyond the limits of (a) to (d). When using the pulse load, a noise sound might be heard from power supply. In addition, it is able to confirm easily that if peak loading condition is matched to the specification by the power matching chart on our website.

#### (a) Peak Output Condition

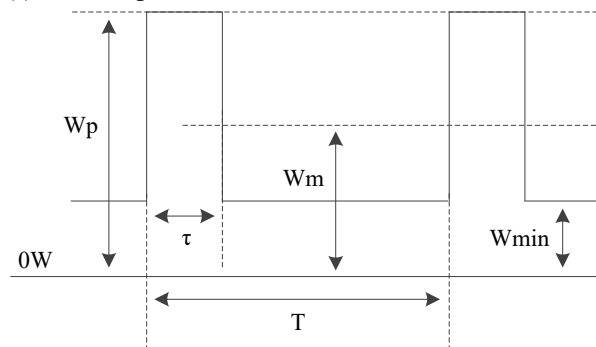

$$W_m \geq \sqrt{W_p^2 \times D + W_{min}^2 \times (1 - D)}$$

- $W_p$  : Peak output power (W)
- $W_m$  : Rated output power (W)
- $W_{min}$  : Output power at light load (W)
- $\tau$  : Pulse width of peak output power (sec)
- $T$  : Period (sec)
- $D$  : Duty

#### (b) Peak Output Power Versus Duty

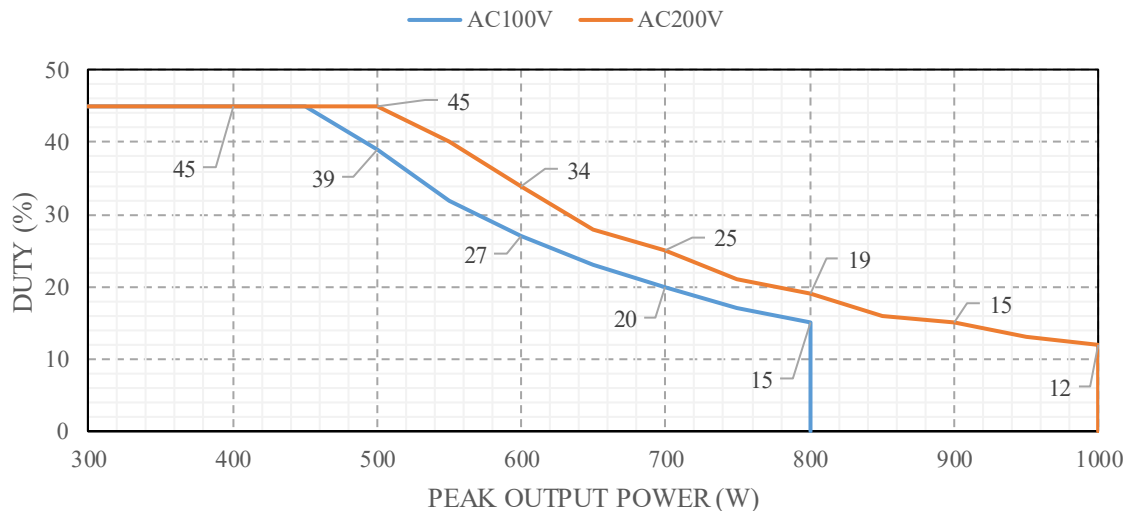

This is representative curve at AC100V and AC200V.  
 For other input voltage condition, refer to power matching chart.

#### (c) Peak Output Power Versus Pulse Width of Peak Output Power

Input voltage, $V_{in}$ (VAC)	Peak output power	Peak pulse width, $\tau$ (sec)
$85 \leq V_{in} \leq 265$	800W	5
$170 \leq V_{in} \leq 265$	1000W	1

**(d) Output Derating curve according to the Input Voltage at Peak Loading**

At peak loading, the following rated output power can be applied for all output voltage models.

**I. Peak output power ( $W_p$ ) is less than or equal to 800W**

Input voltage (VAC)	Rated output power (W)	
	Convection cooling	Forced air cooling
85	280	400
90	290	415
100	315	440
110 to 265	350.4	499.2

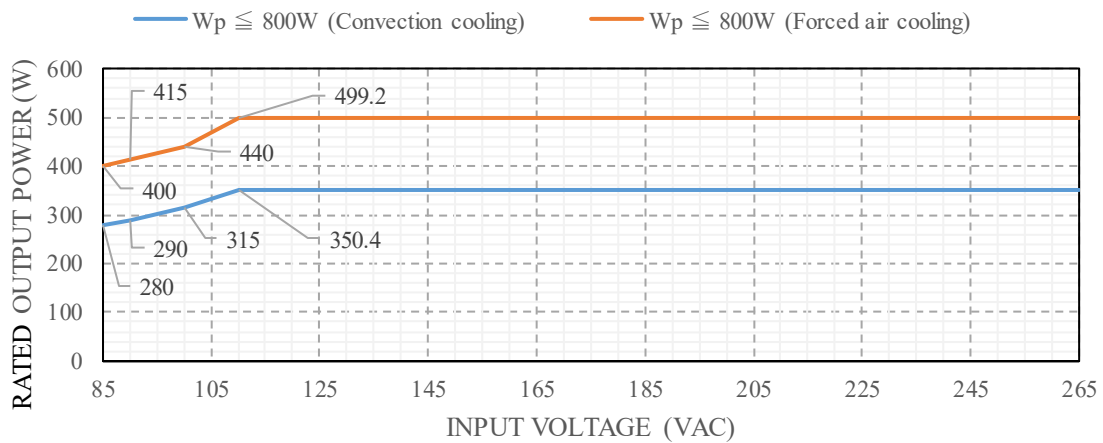

**II. Peak output power ( $W_p$ ) is more than 800W up to 1000W**

Input voltage (VAC)	Rated output power (W)	
	Convection cooling	Forced air cooling
85 to 169	Not applicable	Not applicable
170 to 265	350.4	499.2

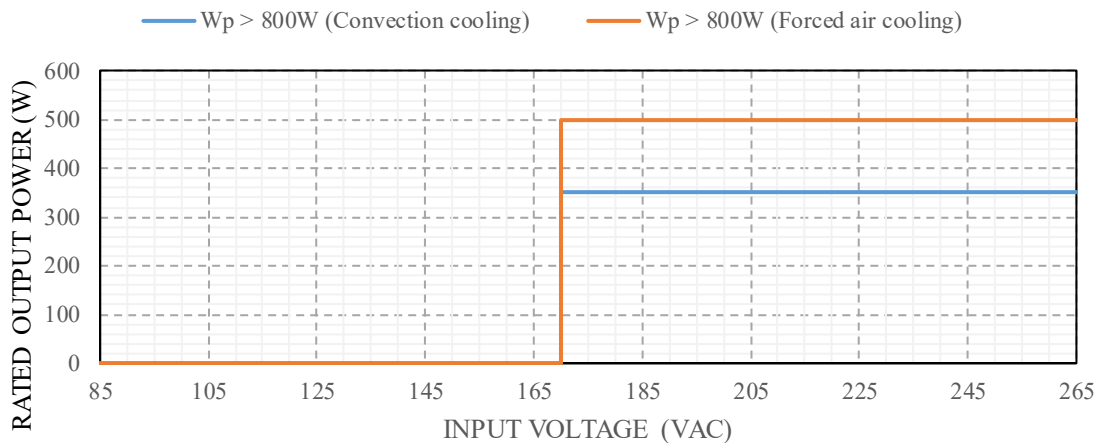

**7-3. Output Derating according to the Mounting Direction**

Load (%) is percent of maximum output power, maximum output current or rated output power at peak loading. For rated output power at peak loading, refer to 7-2 (d). The Output Derating According to the Mounting Direction also must be considered at peak loading.

Standard Model, /T and /CO2 Option Model

**I. CONVECTION COOLING**

Operating ambient temperature (°C)	Load (%)		
	Mounting A	Mounting B, C, F	Mounting D, E
-20 to +20	100	100	100
35	100	100	100
40	100	100	88
50	100	76	65
70	30	30	20

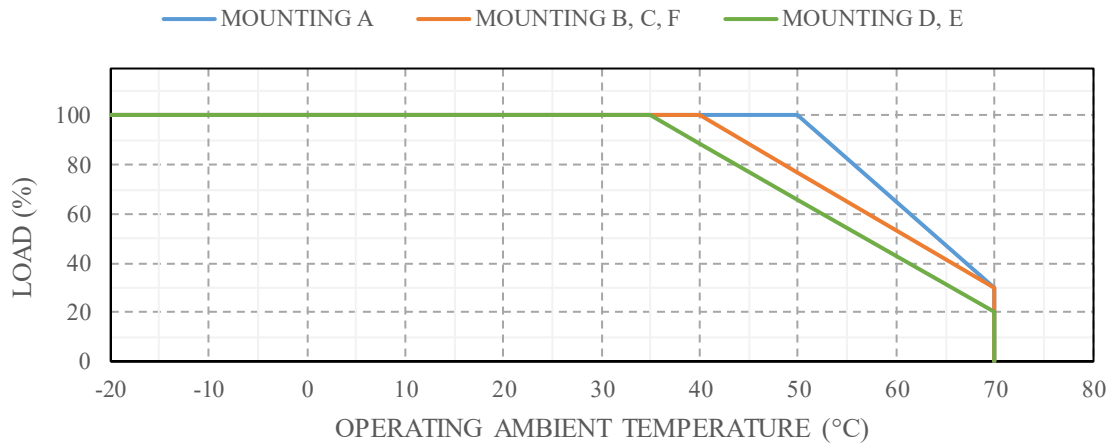

**II. FORCED AIR COOLING**

Operating ambient temperature (°C)	Load (%)
	Mounting A to F
-20 to +70	100

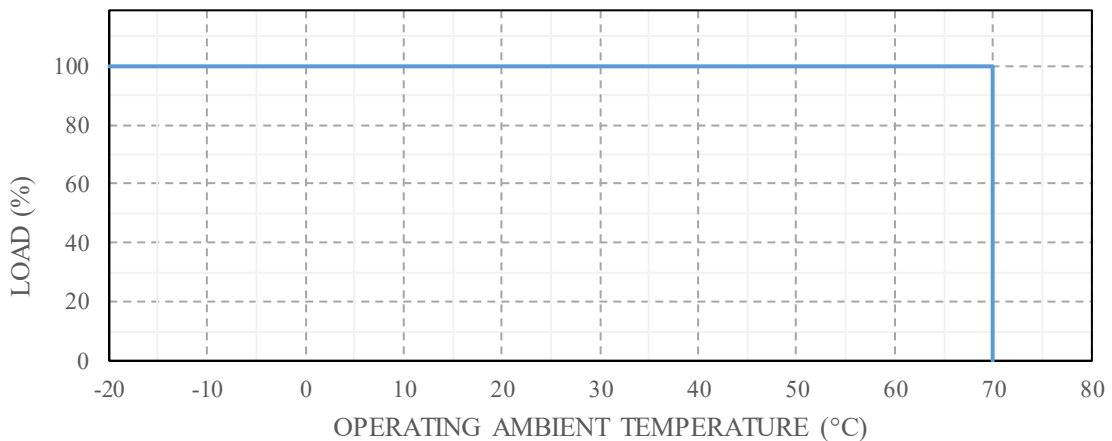

/A and /TA Option Model

**III. CONVECTION COOLING**

Operating ambient temperature (°C)	Load (%)		
	Mounting A	Mounting B, C, F	Mounting D, E
-20 to +20	100	100	100
25	100	100	100
30	100	100	88
40	100	76	65
60	30	30	20

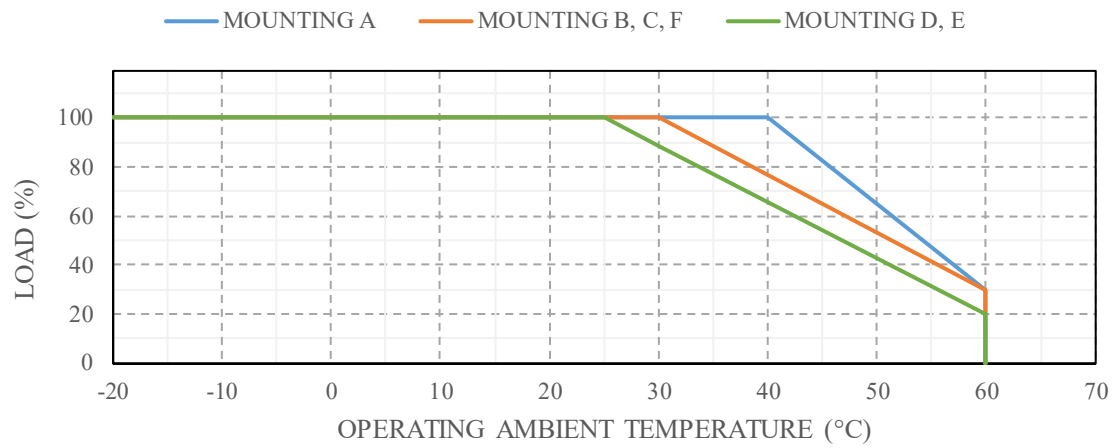

**FORCED AIR COOLING CONDITION**

Components must be cool down. As a guide, an air velocity of more than 2.2m/s is required to flow through the power supply from C9 and T1 side.

The power supply is considered as a component installed to an equipment.

The equipment must be re-evaluated and make sure to meet allowable component temperature.

**ALLOWABLE COMPONENT TEMPERATURE**

Measurement point	Symbol	Item description	Allowable temperature (°C)
A	CN1	Input connector	105
B	C5	Y capacitor	125
C	C6	X capacitor	110
D	C9	Boost capacitor	80(*)
E	C51/C52	Output capacitor	80(*)
F	C12/C58	Signal capacitor	100(*)
G	L2	Input common mode choke coil	125
H	L3	Boost choke coil	130
I	T1	Transformer	130
J	T2	Transformer	130
K	CN51/CN52	Output connector	105
L	PC401/PC402	Photo coupler	110
M	R108	Power resistor	130
N	R51	Power resistor	130

(\*) Electrolytic capacitor. Equipment must be re-evaluated for electrolytic capacitor lifetime.

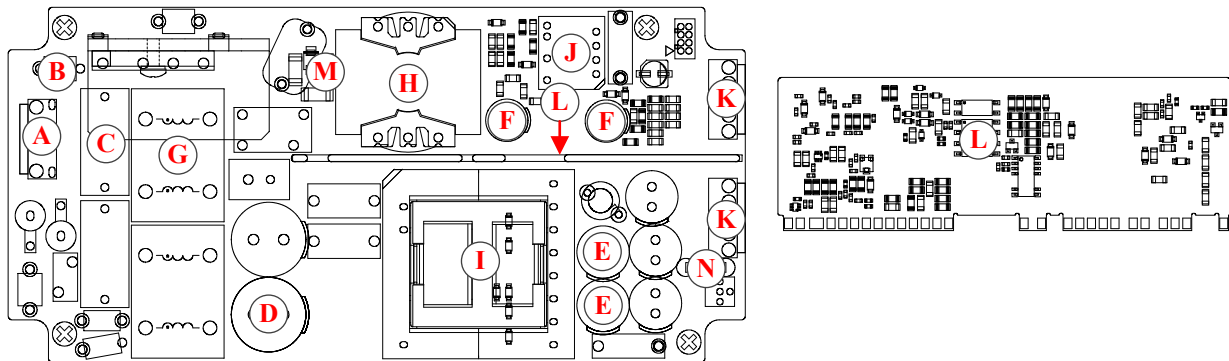

**7-4. Output Derating curve according to the Input Voltage**

Load (%) is percent of maximum output power or maximum output current. In the case of using in peak loading, refer to section 7-2 (d) Output Derating curve according to the Input Voltage at peak loading. In addition, the input derating curve must be considered, refer to section 7-3. Output Derating curve according to the Mounting Direction.

Input voltage (VAC)	Load (%)
85	80
90 to 265	100

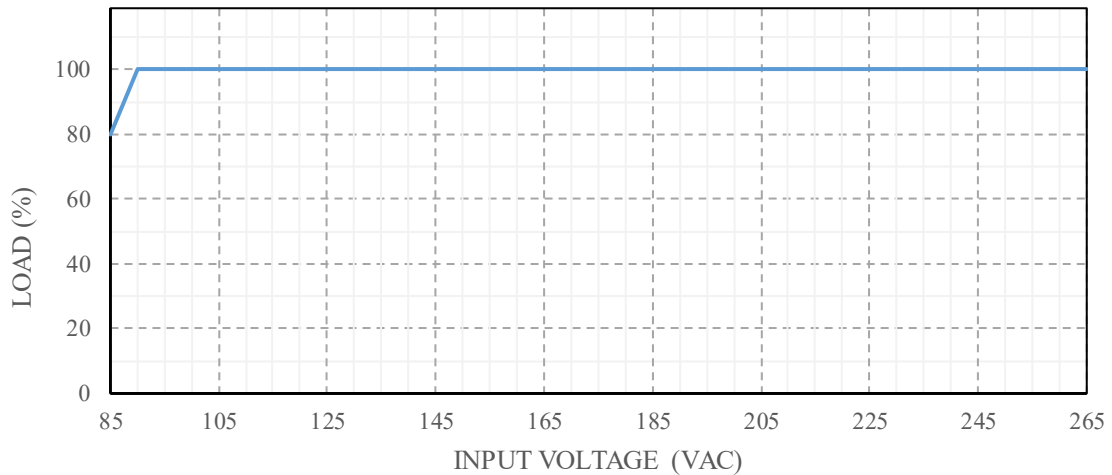

**7-5. Mounting Method**

Standard Model, /T and /CO2 Option Model

Mount the power supply by M3 screw or metal spacer, and use all mounting holes for installation. There is a case where the baseplate becomes high temperature. The equipment should be re-evaluated the power supply to comply the heat resistant temperature of the equipment. User should keep space from the top and surrounding of power supply for convection cooling.

**■ Mounting Holes size**

There are 4 mounting holes (φ3.5mm) available that allow M3 screws or metal spacer to secure power supply.

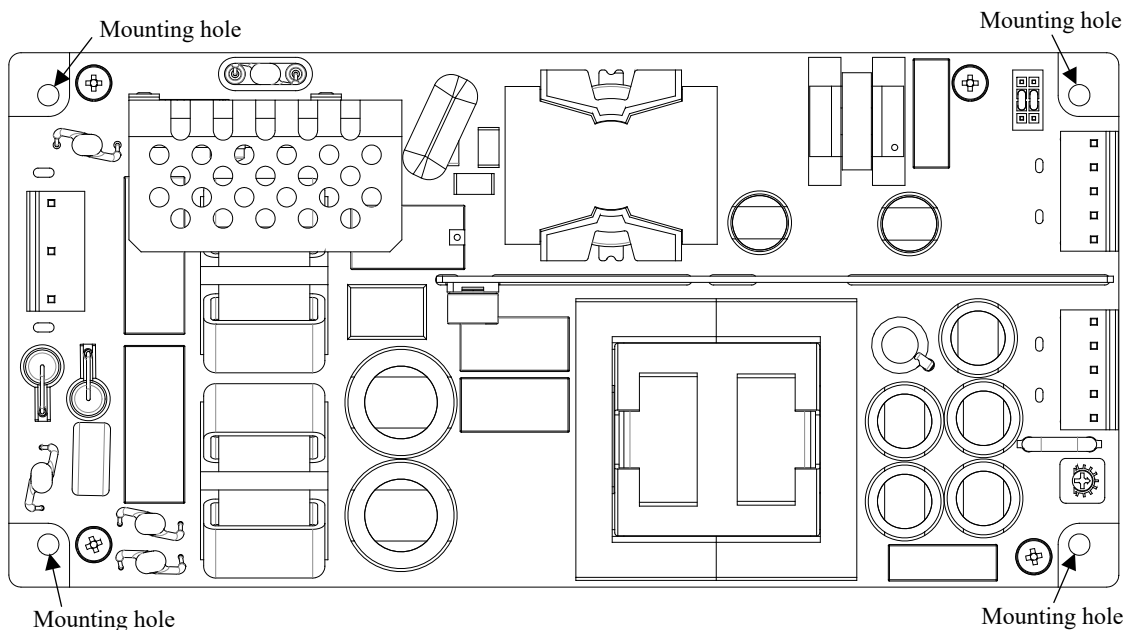

/A and /TA Option Model

Mount the power supply by M4 screw, and use all mounting holes at bottom for installation even if the mounting holes at the side wall is required for installation. The installation by mounting holes at side wall will not be satisfied vibration and shock specification.

■ **Mounting Holes size**

There are 11 mounting holes ( $\phi 4\text{mm}$  or  $\phi 4.5\text{mm}$ ) available that allow M4 screws to secure power supply. Recommended tightening torque is  $1.2\text{ N}\cdot\text{m} \sim 1.6\text{ N}\cdot\text{m}$  ( $12.2\text{ kgf}\cdot\text{cm} \sim 16.3\text{ kgf}\cdot\text{cm}$ )

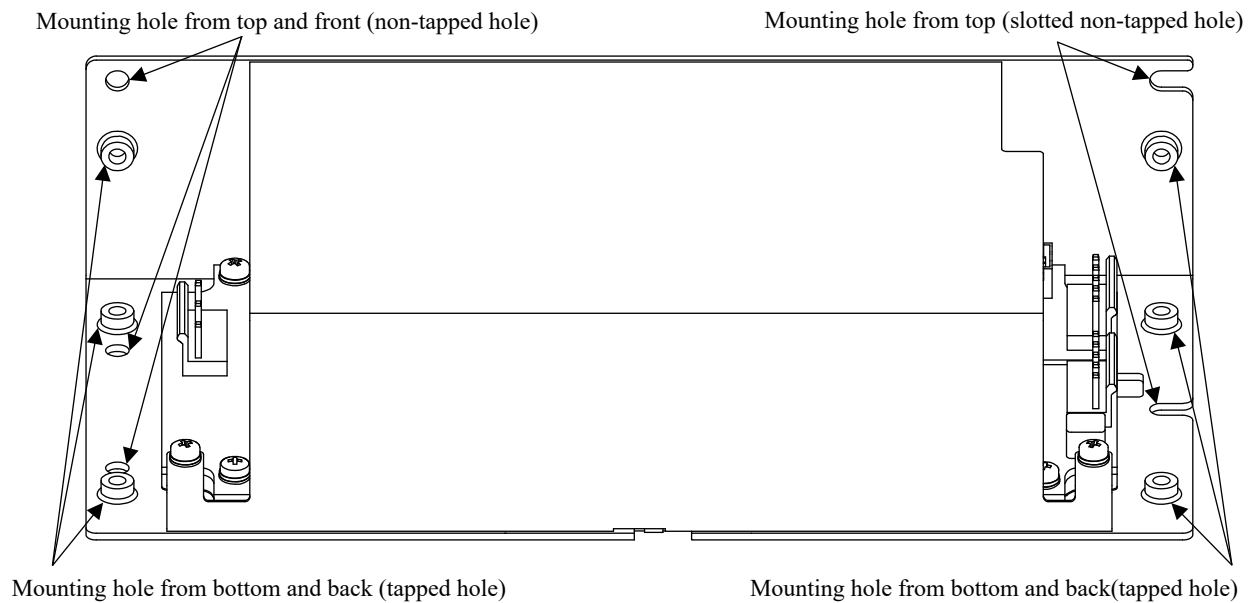

■ **Condition to meet Isolation & Withstand Voltage standard**

Keep 4mm space from the top and surrounding of power supply. If the space is not enough, the specification of isolation and withstand voltage will not be satisfied. Although, user should consider to keep space from the top and surrounding of power supply for convection cooling.

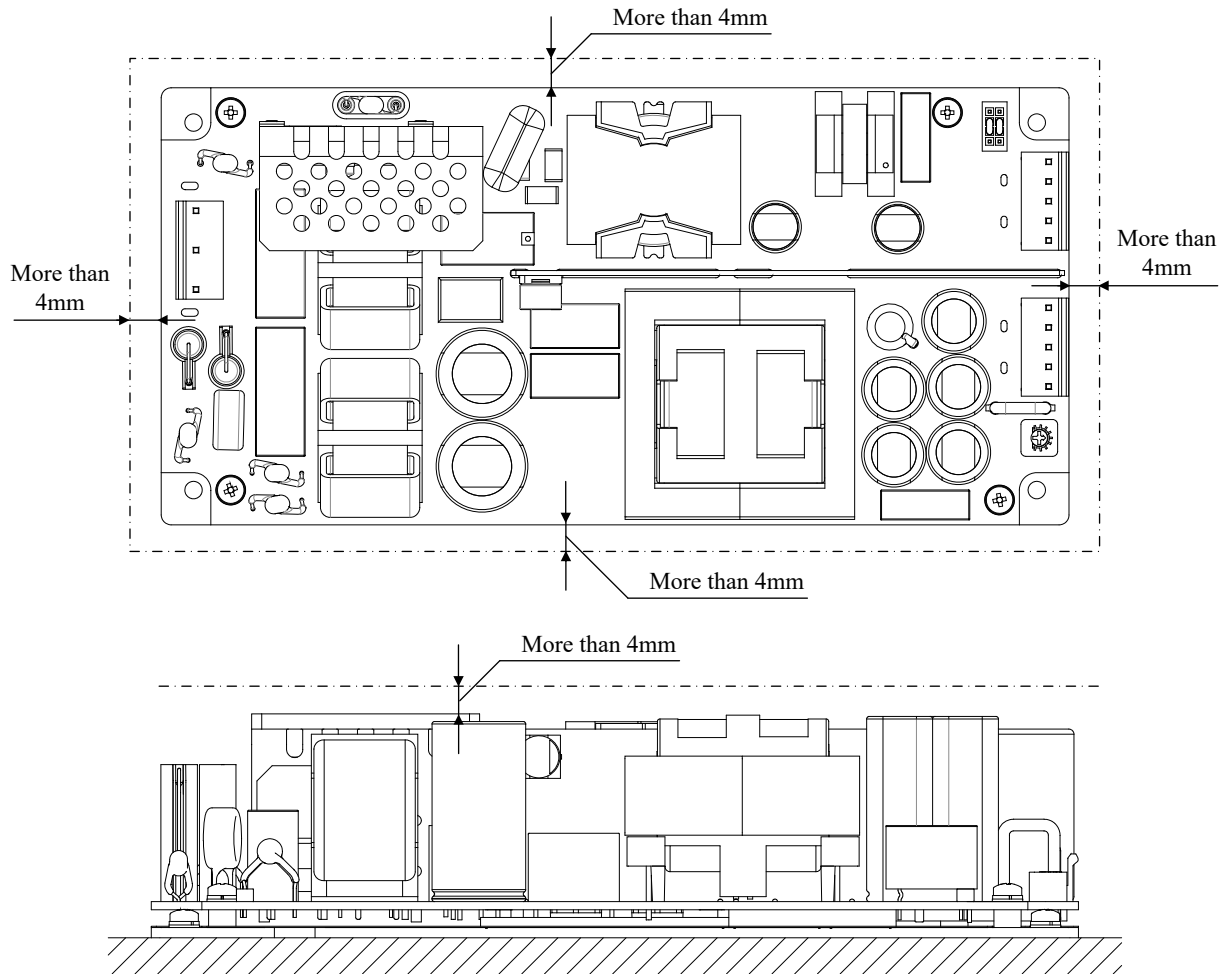

/A and /TA option model are not required to keep same spacing as the image to satisfy isolation and withstand voltage specification. User should consider to keep space from the top and surrounding of power supply for convection cooling.

■ **⊥ terminal**

⊥ terminal should be connected to the protective earth terminal of the equipment. Also 4 mounting holes should be connected to the Chassis (Conductor) by M3 metal screw or metal spacer. If they are not connected, the conducted noise, radiation noise and output noise will increase.

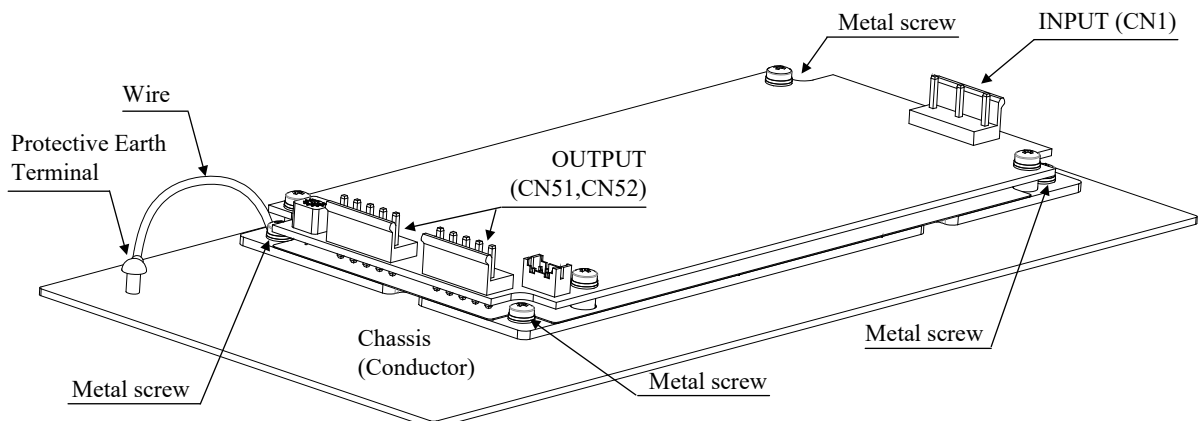

## 8. Wiring Method

- (1) The input and output wiring should be separated from each other and twisted individually. This is to improve noise sensitivity.
- (2) All input and output wiring should be as thick and short as possible to achieve lower impedance.
- (3) Noise can be reduced by attaching a capacitor to the load terminals.
- (4) For safety and EMI considerations, connect between  $\perp$  terminal of input connector and protective earth terminal firmly.
- (5) Use AWG#22 – AWG#16 wire for the input line and output load line.

## 9. The life Expectancy

The life of power supply depends on the lifetime of build-in aluminium electrolytic capacitor and it is described in reliability data. The lifetime of aluminium electrolytic capacitor varies depending on the mounting direction, the load current and the ambient temperature of power supply. Refer to “Electrolytic Capacitor Lifetime” in reliability data. If power supply is used over the life expectancy, there is a risk of unexpected output shutdown and specification might not satisfied.

Please contact to TDK-Lambda for maintenance or exchange the product.

## 10. External Fuse Rating

Refer to the following fuse rating when selecting the external fuse that is to be used on input line. Surge current flows when line turns on. Slow-blow or time-lag type fuse is required to use. Fast-blow fuse cannot use. Fuse rating is considered by in-rush current value at line turn-on. Do not select the fuse according to input current (RMS.) values under the actual load condition.

CME350P-1000 : 16A

## 11. Before concluding that the unit is at fault

- (1) Check if the rated input voltage is connected.
- (2) Check if the wiring of input and output is correct.
- (3) Check if the wire size is not too thin.
- (4) Check if the output current and output power are within specification.
- (5) Check if the output voltage control (V.ADJ) is correctly adjusted.
- (6) Check if the remote ON/OFF control connector is not opened.
- (7) Audible noise can be heard when input voltage waveform is not sinusoidal wave.
- (8) Audible noise can be heard during dynamic load operation.
- (9) Ensure that large capacitor is not connected on output side.

The maximum external capacitance is shown below.

Maximum external capacitor			
24V	30V	36V	48V
10,000uF	8,750uF	7,500uF	5,000uF

## 12. Warranty Period

This product is warranted for a period of 5 years from the date of shipment. For damage occurred during normal operation within this warranty period, repair will be free of charge.